

STANDARD INFORMATION

Amendment 4: See updated effective date in purple below

Amendment 3: See updated effective date in yellow below and addition of April 5, 2022 and October 7, 2022 revisions

Amendment 2: See updated effective date in green below

Amendment 1: See updated effective date in blue below

Standard Number: UL 2034

Standard ID: Single and Multiple Station Carbon Monoxide Alarms [UL 2034:2017 Ed.4+R:07Oct2022]

Previous Standard IDs:

Single and Multiple Station Carbon Monoxide Alarms [UL 2034:2017 Ed.4+R:05Apr2022]

Single and Multiple Station Carbon Monoxide Alarms [UL 2034:2017 Ed.4+R:04Sep2018]

Single and Multiple Station Carbon Monoxide Alarms [UL 2034:2017 Ed.4+R:21Dec2017]

Single and Multiple Station Carbon Monoxide Alarms [UL 2034:2017 Ed.4]

Single and Multiple Station Carbon Monoxide Alarms [UL 2034:2008 Ed.3+R:11May2016]

Single and Multiple Station Carbon Monoxide Alarm [UL 2034:2008 Ed.3+R:26Mar2015]

Single and Multiple Station Carbon Monoxide Alarms [UL 2034:2008 Ed.3+R:20Feb2009]

EFFECTIVE DATE OF NEW/REVISED REQUIREMENTS

Effective Date: ~~May 28, 2021~~ ~~July 7, 2023~~ ~~June 30, 2024~~ ~~June 26, 2026~~ **January 1, 2027**

All reports must be certified to the October 7, 2022 revision, or newer, prior to the effective date of January 1, 2027.

IMPACT, OVERVIEW, AND ACTION REQUIRED

Impact Statement: Per our accreditation, Intertek is required to review reports against the standard revisions to confirm compliance. Once compliance is confirmed, the standard reference in the report is updated to show continued compliance to the technical requirements of the standard. Reports not updated to this version by the effective date above will be withdrawn.



Overview of Changes:

March 26, 2015:

- Revision to Impact Test
- Transient Tests
- Supply Line (Hazardous-Voltage) Transients
- Surge Immunity and Current Tests
- Jarring Test
- Normal Operation Test – Visual Display

May 11, 2016:

- New requirements for battery trouble silence
- Revised requirements for conditioning after tests

March 31, 2017

- New requirements for pre-alarm systems
- New requirements for batteries
- New requirements for Alarm Reset/Silence Feature

December 21, 2017

- New testing sequence for end-of-life signal

September 4, 2018

- Effect of Shipping and Storage

April 5, 2022

- One year sensor stability test for CO sensors

October 7, 2022

- Battery Powered Primary or Secondary Units
- Test Equipment
- New Velocity Sensitivity Test
- Battery Test Requirements

Specific details of new/revised requirements are found in table below.

If the applicable requirements noted in the table are not described in your report(s), these requirements will need to be confirmed as met and added to your report(s) such as markings, instructions, test results, etc. (as required).

Current Listings Not Active? – Please immediately identify any current Listing Reports or products that are no longer active and should be removed from our records. We will do this at no charge as long as Intertek is notified in writing prior to the review of your reports.



STANDARD INFORMATION

CLAUSE	VERDICT	COMMENT
		<i>Additions to existing requirements are <u>underlined</u> and deletions are shown lined-out below.</i>
		The following changes reflect the March 26, 2015 revision
36	Info	Normal Operation Test
36.8		Any indicator of CO concentration shall be accurate to within plus or minus 30% of the indicated amount <u>and display the gas concentration for all Sensitivity tests specified in Table 39.1 and pre/post Sensitivity tests within this standard.</u> No indication shall be given for CO concentrations less than 30 ppm. The indicator shall comply with the in-service reliability requirements of 78.1.2. Testing shall be performed at 70, 150, and 400 ppm and the test data shall be part of the in-service reliability measurement program. <u>For the purposes of these requirements, an indicator of CO concentration shall be either an integral component of a CO alarm or a remote indication provided at an external device, such as a remote receiver or a mobile device, i.e. smart phone.</u>
49	Info	Transient Tests
49.1.2		Different alarms are to be used for each of the four tests in 49.1.1. The alarms shall not false alarm for more than 1 second. Alarms using a primary battery as a power supply are to be subjected to the extraneous transients test only. If an alarm is intended for multiple-station connection, the transient tests are to be conducted with the maximum number of alarms intended to be connected. <u>When a CO alarm is intended for multiple-station connection, the transient tests are to be first conducted with an individual CO alarm, and secondly with two interconnected CO alarms. The interconnecting wiring shall not exceed 12 in (300 mm).</u>
49.2	Info	Supply line (hazardous-voltage ring wave surge voltage) transients
49.2.1		For this test, the alarm is to be connected to a transient generator, consisting of a 2 kilovolt-amperes isolating power transformer and control equipment capable of producing the transients described in 49.2.2. See Figure 49.1. The output impedance of the transient generator is to be 50 ohms. An alarm intended to be powered from commercial AC power shall be subject to supply <u>line transients induced directly between the power supply circuit conductors of the alarm under test.</u>
49.2.2		The transients produced are to be oscillatory and have an initial peak voltage of 6000 volts. The rise time is to be less than 1/2 microsecond. Successive peaks of the transients are to decay to a value of not more than 60 percent of the value of the preceding peak. Each transient is to have a total duration of 20 microseconds. For this test, the product is to be connected to a transient generator capable of producing the Location Category A, 100 kHz Ring Wave transient as defined in <u>IEEE Recommended Practice on Surge Voltages in Low-Voltage AC Power Circuits, ANSI/IEEE C62.41.</u>



CLAUSE	VERDICT	COMMENT
49.2.3		<p>Each unit is to be subjected to 500 oscillatory transient pulses induced at <u>an average rate of once every 10 seconds three pulses every minute</u>. Each transient pulse is to be induced 90 degrees into the positive half of the 60 hertz cycle. A total of 250 pulses is to be applied so that the polarity of the transients is positive with reference to earth ground, and the remaining 250 pulses are to be negative with respect to earth ground.</p>
		<p><i>New sections added;</i></p>
49A & 49B		<p>Surge Immunity Test (Combination Wave) & Surge Current Test</p> <p><i>Rational: To maintain consistency among the UL smoke and detector standards, UL has included surge immunity and surge current test requirements for UL 2034. These tests are identical to those incorporated in UL 217.</i></p>
		<p>Jarring Test</p>
58	Info	<p>Revised Jarring Test – Testing and engineering review required. Jarring test aligns with UL 217, seventh edition.</p>
58.1		<p>While powered by its rated source of supply, and if applicable secondary supply as specified in 35.3.1, An alarm shall withstand jarring resulting from impact and vibration such as might be that experienced in service, without causing an alarm or trouble signal, without dislodgement of any parts, and without adversely affecting its operation impairing its subsequent operation. A momentary audible trouble signal resulting from the jarring is acceptable if the alarm operation is not affected. Dislodgement of parts shall not occur unless the dislodged part(s) does not affect the operation of the unit, there are no hazardous-voltage parts exposed, and the condition is visually obvious.</p> <p><u><i>Exception: A momentary audible trouble signal resulting from the jarring is acceptable if the alarm operation is not affected. Dislodgement of parts is acceptable if the dislodged part(s) does not affect the operation of the unit, and there are no high voltage parts exposed.</i></u></p>
58.2		<p>The alarm and associated equipment, if any, are to be mounted in a position of intended use to the center of a 6 by 4 foot <u>±1/4 inch (1.8 by 1.2 m ±6.25 mm)</u>, nominal 3/4-inch (19.1-mm) thick plywood board which is secured in place at four corners. A 3 foot-pound (4.08 J) impact is to be applied to the center of the reverse side of this board by means of a 1.18-pound (0.54 kg), 2-inch (50.8-mm) diameter steel sphere as shown in Figure 58.1 either swung through a pendulum arc from a height (h) of 2.54 feet (775 mm), or dropped from a height (h) of 2.54 feet (775 mm) to apply 3 foot-pounds (4.08 J) of energy. <u>AC hardwired or AC attachment plug smoke alarms shall be secured to a manufacturer recommend “electrical” box that is secured to the plywood surface.</u></p>
		<p><i>New subsection added;</i></p>
58.2.1		<p>A 3.94 by 3.94 in ±10% (100 by 100 mm ±10%) steel plate, 1/8 in ±10% (3.2 mm ±10%) thick, shall be rigidly secured to the center of the reverse side of the board.</p>



CLAUSE	VERDICT	COMMENT
		<i>New subsection added;</i>
58.2.2		<p>An impact of 3 foot-pounds (4.08 J) shall be applied once to the center of the reverse side of this board by means of a 1.18 pound (540 g), 2 inch (50 mm) diameter steel sphere either:</p> <p>a) Swung through a pendulum arc from a height of 2.54 feet (775 mm) in order to apply 4.08 J of energy; or</p> <p>Dropped from a height of 2.54 feet (775 mm) to apply 3 foot-pounds (4.08 J) of energy, depending upon the mounting of the equipment (see Figure 58.1).</p>
		<i>New subsection added;</i>
58.2.3		<p>The test is to be conducted by supporting the alarm in its intended mounting position and conducting the jarring with the alarm in the standby condition and connected to a rated source of supply in accordance with 35.3.1.</p>
58.3		<p>During this test, the alarm is to be in the standby condition and connected to a rated source of supply in accordance with 35.3.1. Following the <u>jarring test</u>, the alarm shall be tested for <u>sensitivity measurements shall comply with in accordance with 39.1.1.</u></p>
		Impact test
62.5	Info	<p>Revised – Testing may be required. Engineering review required. Impact test is not required for products employing a nonmetallic enclosure and intended for use/installation on the ceiling or no more than 12 inches from the ceiling. Additional markings (83.1.d) and instructions (84.1.t) required if compliant with 62.5.1.1.</p>
62.5.1		<p>An alarm employing a nonmetallic enclosure shall withstand one 5 foot-pound (6.8 N-m) impact without exposure of live parts, impairment of operation, or creation of a risk of electric shock that:</p> <p>a) <u>Does not comply with 62.5.1.1; or</u></p> <p>b) <u>Is for use in recreational vehicles, unconditioned areas, on recreational boats; or</u></p> <p>c) <u>Includes instructions to use an instrument other than remote electronic communication, or a finger or thumb of a person to actuate the test and/or alarm reset/silence feature;</u></p> <p>shall be subject to the requirements outlined in 62.5.1.2, 62.5.2, and 62.5.3.</p>
		<i>New clause added;</i>
62.5.1.1		<p>The Impact Test shall not be required if the alarm is only intended for installation on the ceiling, or on the wall no more than 12 inches from the ceiling. For alarms complying with this installation requirement, it shall be marked with the correct mounting position as noted in 83.1(d) and the installation instructions shall include information as outlined in 84.1(t).</p>



CLAUSE	VERDICT	COMMENT
		<i>New clause added;</i>
62.5.1.2		An alarm shall withstand one 5 foot-pound (6.8 N·m) impact without exposure of live parts, impairment of operation, or creation of a risk of electric shock.
83	Info	Marking (General)
		An alarm shall be permanently marked on a Class IIIC marking material with the following information unless specifically indicated that it appears on the installation wiring diagram. The marking shall be in a contrasting color, finish, or equivalent. Unless the letter height is specified, all markings shall be at least 3/64 inch (1.2 mm) high.
83.1 (d)		d) Correct mounting position if a unit is intended to be mounted in a definite position. <u>Carbon monoxide alarms that comply with 62.5.1.1 shall include marking information that clearly indicates that the product is only intended for installation on the ceiling, or on the wall no more than 12 inches from the ceiling.</u> As an alternative, the correct mounting position shall appear in the installation instructions. <i>Items (a)-(c) and (e)-(u) remain as is</i>
		Each single and multiple station carbon monoxide alarm shall be provided with installation instructions which shall include the following information:
84.1 (t)		t) <u>Products that comply with 62.5.1.1 and are not subjected to the Impact Test, 62.5, shall include information clearly indicating that the user shall actuate the test and/or alarm reset/silence feature remotely (via an electronic signal or aerosol test gas), or by use of a person's finger or thumb, and that the use of any other instrument(s) is strictly prohibited.</u> <i>Items (a)-(s) remain as is</i>



CLAUSE	VERDICT	COMMENT
The following changes reflect the May 11, 2016 revision		
39	Info	Circuit Measurement Test
39.3	Info	Battery trouble silence
		<i>New clause added;</i>
39.3.1		The battery trouble signal from each of three alarms may be temporarily silenced until the battery capacity reaches the trouble level voltage-resistance points described in 39.2.2. The battery trouble signal must restore and no longer be capable of being silenced when the trouble level voltage-resistance points described in 39.2.2 have been reached.
79	Info	Carbon Monoxide Alarms for Use on Recreational Boats
79.2	Info	Operation tests following conditioning
		<i>New clause added;</i>
79.2.1		Immediately following each of the conditions specified in 79.2.3 – 79.2.17, and while in the environmental condition specified in 79.2.3 and 79.2.4, the alarms shall be subject to the Sensitivity Tests specified in Section 41. The sensitivity readings shall not, in any case, exceed the limits specified in Table 41.1, Part A – Alarm, and Table 41.1, Part B – False alarm, except the 30-day test is to be conducted for 8 hours.
79.2.2		The tests specified in 79.2.3 and 79.2.4 <u>shall be conducted in sequential order as outlined in this standard</u> . The same samples used for 79.2.3 and 79.2.4, including remote sensors, are to be used for all tests defined in 79.2.3 – 79.2.17. These samples are to be energized during each environmental exposure.
79.2.3		Three sample alarms are to be placed in an air-circulating oven maintained at 70 ±2°C (158 ±4°F) <u>with a relative humidity of 20 ±2.5 percent</u> for 24 hours.
		<i>New clause added;</i>
79.2.4		Immediately following the conditioning specified in 79.2.3 and the sensitivity test specified in 79.2.1, the following is to be conducted: a) It is not prohibited that the same alarms remain powered and are allowed to pre-condition at the ambient condition specified in 41.2 or gradually transition to the ambient condition specified in 41.2 by turning off the variable ambient chamber and opening the environmental chamber door. The samples are allowed to remain in the ambient condition specified in 41.2 for a maximum of 16 hours prior to initiating the next ambient temperature of minus 40. This 16 hour time period of pre-conditioning is to include the time required to transition to the ambient condition specified in 41.2. The time period to transition to the ambient condition specified in 41.2 shall not exceed 4 hours; or



CLAUSE	VERDICT	COMMENT
		<p>b) The samples are to remain in the chamber, without powering down the samples, and without removing the samples from the chamber. The environmental chamber is to be set to transition to the next environmental condition as quickly as possible. The transition temperature and humidity from 79.2.3 to the next environmental condition shall not exceed 60 minutes.</p> <p>The environmental chamber is to be set to minus 40 ±2°C (minus 40±4°F) with a relative humidity of 45 +10 percent/ -5 percent for 24 hours. The environmental chamber temperature and relative humidity are to be controlled to ensure that the transition between temperatures does not result in a condensing environment.</p>
		<p><i>New clause added;</i></p>
79.2.5		<p>Following each environmental condition specified in 79.2.3 and 79.2.4, the sensitivity tests are to be conducted at the conclusion of the 24-hour conditioning environment.</p>
		<p><i>New clause added;</i></p>
79.2.6		<p>Sensitivity testing shall not be conducted during the pre-conditioning of the samples as specified in 79.2.4 (a) and (b).</p>
<p>The following changes reflect the March 31, 2017 revision</p>		
7	Info	<p>Battery Removal Indicator</p> <p><i>New clause added;</i></p> <p>Deactivation of the battery of a carbon monoxide alarm that uses a non-replaceable battery shall result in a readily apparent and prominent indication. The indication shall consist of one of the following:</p>
7.2		<p>a) A warning flag that will be exposed with the battery removed and the cover closed;</p> <p>b) A hinged cover that cannot be closed with the battery removed;</p> <p>c) A swing-out or pull-out battery compartment that is resistant to being closed unless it has a battery in place;</p> <p>d) An audible or audible and tactile trouble signal on an AC powered carbon monoxide alarm with battery back-up;</p> <p>e) An arrangement to render the unit resistant to reinstallation; or</p> <p>f) A local audible, local audible and tactile, or local visual indication at the control panel.</p>
		<p><i>New clause added;</i></p>
7.3		<p>If a warning flag, or equivalent, is employed to comply with the requirement of 7.1 or 7.2, it shall be marked as required in 87.6.</p>



CLAUSE	VERDICT	COMMENT
8		<i>New section added;</i>
		Alarm Reset/Silence Feature
8.1		Each single and multiple station carbon monoxide alarm shall be designed to be reset/silenced through a manual operation (on the alarm) by physically depressing the alarm reset/silence feature. The operation of the reset/silence feature shall silence the alarm signal and restore the alarm to its normal condition resulting in the alarm once again being able to sense carbon monoxide and alarm within the limits of the Sensitivity Test, Section 41. The alarm signal shall be reenergized within 6 minutes from the time the reset button is operated if the concentration of carbon monoxide surrounding the alarm remains at 70 ppm or greater.
8.2		When single station carbon monoxide alarms are configured in a multiple station connection (interconnection of two or more carbon monoxide alarms), the carbon monoxide alarm that initiates an alarm signal shall be designed to be reset/silenced through a manual operation by physically depressing the alarm reset/silence feature on the initiating alarm.
8.3		As an optional feature, the manufacturer is permitted to include an additional wireless communication remote reset/silencing feature. If included, and tested for compliance with the requirements outlined in 8.6, the wireless communication remote reset/silence feature may be activated through a remote device. The wireless communication feature shall be capable of providing additional instructions for the user to confirm his physical proximity to the initiating carbon monoxide alarm before resetting/silencing the alarm signal using the remote device.
8.4		A multiple-station interconnected carbon monoxide alarm that produces an alarm signal (wired, wireless, relay, audible and audible-visual) shall be permitted to be reset/silenced by any of the following: a) By activating the alarm reset/silence feature on any multiple station interconnected carbon monoxide alarm, provided the carbon monoxide alarm that initiated the alarm signal remains in alarm; or b) By physically depressing the alarm reset/silence feature on the initiating carbon monoxide alarm(s), as noted in 8.1; or c) By activating the wireless communication remote reset/silencing feature using a remote device.
8.5		Upon activation of an alarm signal from a carbon monoxide alarm in the multiple-station circuit, or reactivation of the alarm signal from the originating carbon monoxide alarm, all alarms in the multiple-station interconnect shall re-initiate their alarm signal.
8.6		Carbon monoxide alarms with a wireless communication remote device and employing a remote alarm reset/silence feature shall be tested in accordance with one of the following requirements:



CLAUSE	VERDICT	COMMENT
		<p>a) The remote transmission radio of the carbon monoxide alarm shall comply with FCC Part 15.249 and the following frequency and field strength requirements:</p> <ol style="list-style-type: none"> 1) Frequency range <ol style="list-style-type: none"> i) 2.4 GHz (2.4 GHz – 2.4835 GHz) ii) 900 MHz (902 – 928 MHz) iii) 5.8 GHz (5725 – 5875 MHz) 2) Field strength <ol style="list-style-type: none"> i) 94 dBuV/m @ 3m <p>or</p> <p>b) The remote transmission radio of the carbon monoxide alarm shall comply with FCC Part 15.247 and the following frequency and field strength requirements:</p> <ol style="list-style-type: none"> 1) Frequency range <ol style="list-style-type: none"> i) 2.4 GHz (2.4 GHz – 2.4835 GHz) ii) 900 MHz (902 – 928 MHz) iii) 5.8 GHz (5725 – 5875 MHz) 2) Field strength <ol style="list-style-type: none"> i) 30 dBm (1 W) (using antennas with directional gains < 6 dBi) <p>or</p> <p>c) The manufacturer shall provide a defined test procedure, test frequency and field strength in compliance with FCC regulations that demonstrate the open field (line of sight) transmission range of the carbon monoxide alarm does not exceed 984 ft (300 m).</p>
16	Info	Secondary Power Supply
16.1		<p>The use of a secondary power supply is optional <u>required</u> for all alarms that receive their primary power from a source other than an integral battery or batteries. The secondary power supply, such as a battery, shall have the capacity to supply the maximum intended power to the alarm for 8 <u>24</u> hours in the standby condition and thereafter be able to operate the alarm for an alarm signal for at least 12 hours continuously, followed by not less than 7 consecutive days of trouble signal.</p>
16.4		<p>If the discharge condition of a nonrechargeable type battery cannot be discerned visually, some form of test means, or equivalent, shall be provided to determine battery capacity. Any of the following are suitable means:</p> <ol style="list-style-type: none"> a) Battery test switch with related meter or equivalent means to indicate battery capacity. b) Monitored battery where a trouble indication, as described in 38.1.3, is obtained. <p><u>The discharge condition of a non-rechargeable or rechargeable type battery shall be monitored where a trouble indication, as described in 40.1.3, is obtained. The monitoring shall take place whether the alarm is operating on the primary supply or on the standby supply.</u></p>



CLAUSE	VERDICT	COMMENT
17	Info	Batteries
17.1	Info	General
		<i>New clause added;</i>
17.1.6		A carbon monoxide alarm powered by a non-replaceable battery shall be provided with a means of activating the power prior to installation and deactivating the battery at the end of the useful battery life. The deactivation means shall require the use of a tool, or equivalent, and shall render the unit resistant to being reinstalled. The deactivation means shall also serve to discharge the battery(ies) completely. Both the activation and deactivation means shall be designed to operate one time only. The installation instructions shall provide the user with information describing this one time operation. See 88.1(u).
39	Info	Circuit Measurement Test
		<i>New section added;</i>
39.2		Battery trouble voltage determination
39.2.1		An increase in the internal resistance, or a decrease in terminal voltage, of a battery employed as the primary or secondary source of power to an alarm shall not impair operation for an alarm signal before a trouble signal is obtained. In addition, any combination of voltage and resistance at which a trouble signal is obtained shall be greater than the battery voltage and resistance combination measured over a 12 month period in the room ambient condition of the Battery Tests, Section 64.
39.2.2		The trouble level of a battery operated carbon monoxide alarm shall be determined (using the test circuit in Figure 39.1 and the voltage-resistance curves of Figure 39.2) for each of the following voltages: a) Rated battery voltage, b) Trouble level voltage (assuming minimal or no series resistance), and c) Voltages between rated and trouble level voltage.



Test circuit

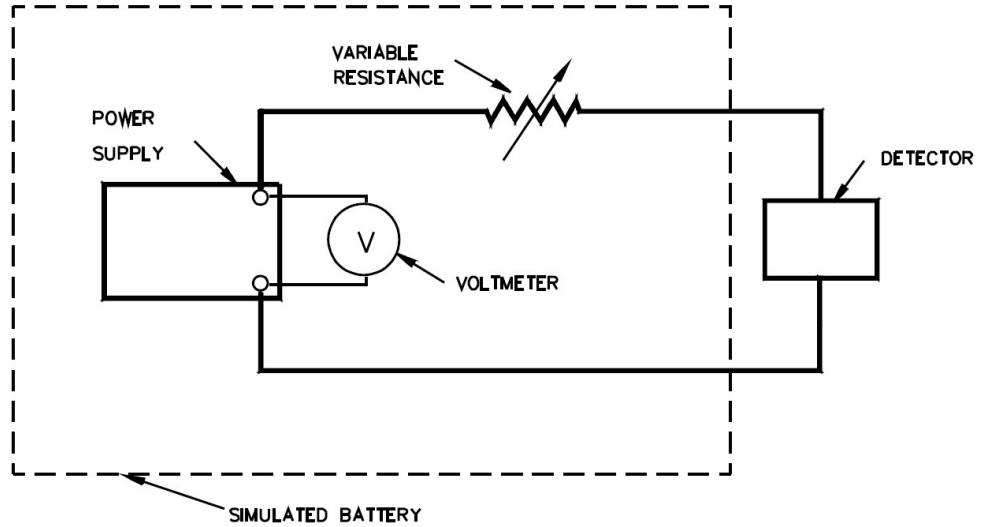

Figure 39.1

Trouble level determination graph

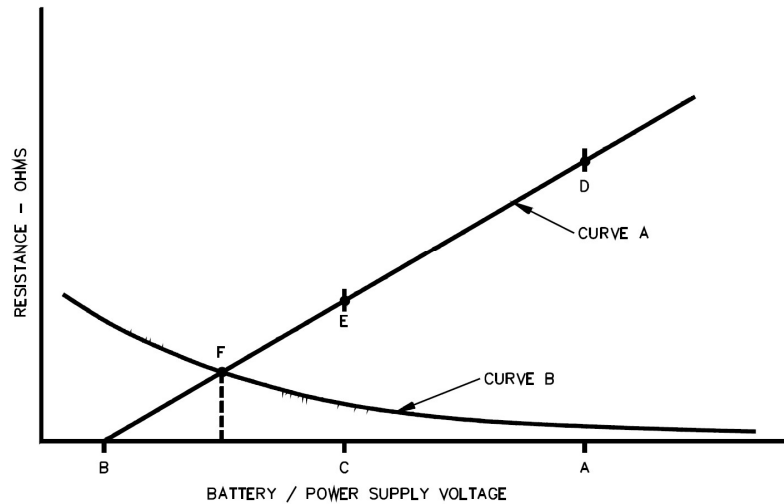

Figure 39.2

- A – Rated battery voltage.
- B – Trouble level voltage (assuming minimal resistance).
- C – Voltage value between rated and trouble level.
- D – Trouble level resistance at rated battery voltage.
- E – Trouble level resistance at voltage value C.
- F – Maximum permissible battery resistance and minimum voltage after 6 months in long-term battery test.

Curve A – Sample plot of voltage vs. resistance (alarm trouble level curve) at which a trouble signal in an alarm is obtained. Audibility measurement is to be made at points between D and F.



CLAUSE	VERDICT	COMMENT
		Curve B – Sample plot of battery internal resistance vs. battery open circuit voltage derived from long term (minimum 6 months) battery test. Shape and slope of curve, as well as point of intersection with Curve A, will vary depending on battery used.
38.2.3		<p>To determine compliance with 39.2.1 each of three alarms is to be connected in series with a variable regulated direct current power supply and a variable resistor as illustrated in Figure 39.1. The trouble level is to be determined by the following steps:</p> <p>a) Rated Battery Voltage – The voltage of the power supply is to be set at the rated battery voltage and the series resistor at 0 ohms. The resistance is to be increased in increments of 0.1 – 10 ohms, at a rate of not more than one increment per minute, until a trouble signal is obtained. The alarm is to be tested for alarm operation at each resistance level and at the trouble signal level.</p> <p>b) Trouble Level Voltage – With the variable resistor set at 0 ohms, the voltage of the power supply connected to the alarm is to be reduced in increments of 1/10 volt per minute to the level where the trouble signal is obtained. The alarm is to be tested for alarm operation at each voltage level and at the trouble signal level.</p> <p>c) Voltage Values Between Rated and Trouble Level Voltages – The voltage of the power supply is to be set at preselected voltages between the rated battery voltage and the trouble level voltage. The series resistance is then to be increased in increments of 0.1 – 10 ohms, at a rate of not more than one increment per minute, until a trouble signal is obtained. The alarm is to be tested for alarm operation at each resistance and voltage level and at the trouble voltage level. A sufficient number of voltage values shall be selected to determine the shape of the trouble level curve.</p>
39.2.4		To determine that a battery is capable of supplying alarm and trouble signal power to the alarm for at least 12 months under the room ambient condition described in the Battery Tests, Section 64, Curve A of Figure 39.2 is to be plotted from the data obtained in the measurements described in 39.2.3 and compared to Curve B of Figure 39.2, which is plotted from data generated in the 6 months battery test. The intersection of Curves A and B shall not occur before 12 months and all points of Curve B to the right of point F (extended to the base line), shall be below Curve A.
40	Info	Electrical Supervision Test
40.1	Info	General
40.1.3		If an audible trouble signal is required to indicate a fault condition, it shall be produced every 30 – 60 seconds ± 10 percent for a minimum of seven consecutive days. The trouble signal shall be distinctive from the alarm signal <u>and, if provided, pre-alarm signal.</u>
40.2	Info	AC powered units
40.2.2		Neither loss nor restoration of power shall cause an alarm signal under either momentary or extended (at least 1/2 hour) power outage conditions. Momentary



CLAUSE	VERDICT	COMMENT
		energization of the alarm circuit (maximum of 1 second), and energization of the trouble circuit (maximum of 2 minutes), is not considered an alarm signal. A gradual increase to 110 percent of rated voltage or reduction to 0 volts from rated voltage at a rate of not greater than 5 volts per minute shall not result in energization of the alarm (or pre-alarm) signal for more than 1 second.
40.2.3		Loss of power to a single unit of a multiple station alarm configuration, while energized in the standby condition, shall not result in a false alarm (or pre-alarm) and shall not prevent the operation of the remaining units for alarm.
40.3	Info	Battery powered primary or secondary units <i>New clause added;</i>
40.3.5		An alarm which uses a battery (or other applicable rechargeable energy storage media) as the secondary source of supply shall be capable of supplying the carbon monoxide alarm with a minimum of 24 hours of power in the normal standby condition. The carbon monoxide alarm shall be capable of producing an alarm signal for at least 12 hours at the battery voltage at which an audible trouble signal is obtained followed by 7 days of audible trouble signal indication.
40.3.6		To determine compliance with 40.3.5 for alarms whose secondary supply is a battery (or other applicable rechargeable energy storage media), three samples shall be powered from secondary sources of supply (with the primary source of supply disabled) which are fully charged, or in fresh condition (see 37.2, Secondary power supply) and allowed to remain in the normal standby condition for a minimum of 24 hours. The samples shall not emit audible low battery trouble signals before the end of the 24 hour period. Three samples shall also be equipped with secondary supplies (with the primary source of supply disabled) which have been depleted to the trouble signal level. The samples are then to be placed in alarm for 12 hours. Following the 12 hours of alarm the trouble signal shall persist for at least 7 consecutive days. It is possible to deplete a fresh battery by applying a 1 percent or smaller loading factor based on the ampere hour rating of the battery. For example, a 1000 milliampere-hour rated battery is depleted by applying a 10 milliampere (1 percent load) or less drain continuously until the battery voltage reaches the predetermined test level.
41	Info	Sensitivity Test
41.1	Info	General
41.1.2		A carbon monoxide alarm shall not operate (alarm signal) below the test points specified in Part B of Table 41.1, when using the test equipment described in 41.2.1. If the alarm employs a variable sensitivity setting, test measurements are to be made at maximum and minimum settings. For this test, at least two carbon monoxide concentrations (70 and 30 ppm) are to be used as specified in Part B of Table 41.1. It is not prohibited for a pre-alarm signal to occur prior to the exposure time specified for the test points outlined in Table 41.1 provided the gas concentration is in excess of 30 ppm carbon monoxide.



CLAUSE	VERDICT	COMMENT
42	Info	Selectivity Test
42.1		The alarm (or pre-alarm) shall not sound when an alarm is exposed sequentially, as described in 42.3 – 42.6, to the concentrations of gases and vapors shown in Table 42.1. These substances are intended to represent air contaminants found in the vicinity of an installed alarm.
43	Info	Sensitivity Test Feature
43.1		A sensitivity test feature shall be provided on a carbon monoxide alarm, to simulate either mechanically or electrically a specified level of carbon monoxide in the sensing chamber. The test feature shall be manually operated and accessible from outside the alarm, with the alarm installed as intended. The maximum permissible measured level shall not exceed 400 ppm. The test feature when operated shall result in an audible alarm signal of at least two full cycles to allow the user of the alarm device to become familiar with the sound of the alarm.
		<i>New clause added;</i>
43.2		As an optional feature, the manufacturer is permitted to include an additional wireless communication remote test feature. If included and tested for compliance with the requirements outlined in 43.3, the remote test feature may be activated through a remote device.
		<i>New clause added;</i>
		Carbon monoxide alarms with a wireless communication remote device and employing a remote test feature shall be tested in accordance with one of the following requirements:
43.3		a) The remote transmission radio of the carbon monoxide alarm shall comply with FCC Part 15.249 and the following frequency and field strength requirements: <ul style="list-style-type: none">1) Frequency range<ul style="list-style-type: none">i) 2.4 GHz (2.4 GHz – 2.4835 GHz)ii) 900 MHz (902 – 928 MHz)iii) 5.8 GHz (5725 – 5875 MHz)2) Field strength<ul style="list-style-type: none">i) 94 dBuV/m @ 3m
		or
		b) The remote transmission radio of the carbon monoxide alarm shall comply with FCC Part 15.247 and the following frequency and field strength requirements: <ul style="list-style-type: none">1) Frequency range<ul style="list-style-type: none">i) 2.4 GHz (2.4 GHz – 2.4835 GHz)ii) 900 MHz (902 – 928 MHz)iii) 5.8 GHz (5725 – 5875 MHz)2) Field strength



CLAUSE	VERDICT	COMMENT
		i) 30 dBm (1 W) (using antennas with directional gains < 6 dBi)
		or
		c) The manufacturer shall provide a defined test procedure, test frequency and field strength in compliance with FCC regulations that demonstrate the open field (line of sight) transmission range of the carbon monoxide alarm does not exceed 984 ft (300 m).
44.1, 48.1.1, 49.1.1, 49.2.1, 51.1.2, 51.4.1, 58.1, 62.1, 75.1, 77.1, 78.1, 79.3.1, 79.4.1		For each of these performance tests, pre-alarm was added to the criteria for each test. The units shall not produce a pre-alarm signal as identified in the referenced tests. This applies only when a pre-alarm signal is used.
59	Info	Static Discharge Test
59.1		The components of an alarm shall be shielded so that its operation is not adversely affected when subjected to static electric discharges. Operation of the trouble circuit during this test is not considered a failure if the subsequent operation of the alarm is not impaired. Operation of the alarm (<u>or pre-alarm</u>) shall terminate in less than 5 seconds. The test is to be conducted in an ambient temperature of 23 ±3°C (73.4 ±5°F), at a relative humidity of 10 ±5 percent, and a barometric pressure of not less than 700 mm of mercury (93 kPa).
69	Info	Polarity Reversal Test
69.1		A carbon monoxide alarm shall operate as intended after being connected in each polarity. While energized under either polarity, the alarm shall comply with the requirements of the Electric Shock Current Test, Section 70. This includes cord connected and fixed wiring (splice lead) types, battery types (main or standby) and multiple station interconnection leads. Each polarity is to be applied for at least 24 hours on all units unless a trouble signal or alarm (<u>or pre-alarm</u>) signal is obtained. For battery operated alarms intended to be connected by a polarized clip assembly, the reverse polarity is to be applied for a minimum of 1 second. A trouble or alarm (<u>or pre-alarm</u>) signal is to be not prohibited under any incorrect polarity applied. A maximum 1-second alarm is not prohibited when the correct polarity is connected.
79	Info	Carbon Monoxide Alarms for Use on Recreational Boats
79.8	Info	Operating and installation instructions
79.8.1		Each alarm shall be provided with installation and operating instructions that include the following information: f) Information regarding the alarm and an indication where false alarms (<u>or pre-alarm</u>) are to be anticipated;



CLAUSE	VERDICT	COMMENT
	Info	MARKING
87	Info	General
87.1		<p>An alarm shall be permanently marked on a Class IIIC marking material with the following information unless specifically indicated that it appears on the installation wiring diagram. The marking shall be in a contrasting color, finish, or equivalent. Unless the letter height is specified, all markings shall be at least 3/64 inch (1.2 mm) high.</p> <p>l) Distinction between alarm, <u>pre-alarm</u>, end-of-life, and trouble signals on units employing these signals.</p>
	Info	INSTRUCTIONS
88	Info	General
88.1		<p>Each single and multiple station carbon monoxide alarm shall be provided with installation instructions which shall include the following information:</p> <p>f) More detailed information on the alarm, <u>pre-alarm</u>, end-of-life, and trouble signals and an indication where false alarms or trouble signals would be anticipated; such as to reduce the possibility of nuisance tripping of the alarm's alarm circuit, the instructions shall state that accommodation spaces are to be well ventilated when household cleaning supplies or similar contaminants are used. The end-of-life information shall include details on how long the unit may be expected to last and shall indicate if the end-of-life is based on the date the unit was manufactured or the date that the user places the unit into service.</p> <p><u>u) For alarms powered by a non-replaceable battery, the instructions shall provide a description of the proper use of the battery activation and deactivation features. This information shall specify that each feature is intended for one time use only.</u></p>
88.4		<p><i>New clause added;</i></p> <p>For multiple-station interconnected carbon monoxide alarms with alarm reset/silencing means, other than physically depressing the reset/silence button, the resetting/silencing of the initiating alarm shall describe the following:</p> <p>a) An example and information detailing the alarm information as communicated to the user. The remote silencing device shall provide instructions to the user as noted in item (b) below after the user attempts to activate the remote reset/silence feature;</p> <p>b) At a minimum, all instructions and the remote device (if provided) shall include instructions to the user to move to fresh air upon activation of an alarm signal.</p>



CLAUSE	VERDICT	COMMENT
The following changes reflect the December 21, 2017 revision		
40	Info	Electrical Supervision Test
40.1	Info	General
		<p>The unit Units powered by electrical (AC) mains, or primary and/or secondary battery power source shall indicate end-of-life, based on the manufacturer's specified lifetime, with an end-of-life signal (see 5.12). It is permitted for the audible component of the signal to be of the same format as a trouble signal, provided a visual indicator is employed to differentiate between the end-of-life and other trouble conditions. The end-of-life signal shall repeat once every 30 – 60 seconds ± 10 percent. This signal shall be triggered either by an internal timer or by a self-diagnostic test(s).</p>
40.1.6		<p>a) For a unit that employs a signal generated by an internal timer, once maximum specified lifetime is reached the end-of-life signal shall be initiated. The timer can be reset repeatedly, for a period not exceeding 72 hours for each period of reset, if self-diagnostic test(s) indicate that the unit still meets the requirements of this standard. The timer shall not be able to be reset after 30 days following the initial end-of-life signal. <u>The manufacturer shall provide detailed documentation of the timer operation that includes, a description of how the timer data is affected by either short or long term removal of power to the alarm.</u></p> <p>b) For a unit that employs a signal generated by a self-diagnostic test, once this test has determined the device no longer meets the requirements of this standard, the end-of-life signal shall be initiated.</p> <p>c) If the sensor is automatically and periodically tested for response to CO (or an equivalent gas), then the unit's specified lifetime calculations can exclude the sensor component.</p>
		<p><i>New clause added;</i></p> <p>In addition to the requirements outlined in 40.1.6 a), b) and c), two alarms employing a replaceable battery or batteries shall be subject to the following requirements in the following order:</p>
40.1.7		<p>a) The end-of-life signal on an alarm shall be reset only once, as based on the manufacturer's recommendations.</p> <p>b) If powered by AC mains or DC mains (Recreational Vehicle and/or Marine Use) the primary power shall first be disconnected prior to removing and installing the replacement battery.</p> <p>c) The installed battery (original) shall be replaced with a new battery.</p> <p>d) The new battery shall not be replaced within 15 minutes from removing the original battery. Manufacturer must provide detailed information that outlines the minimum amount of time needed to ensure that the residual power on the alarm has been depleted.</p>



CLAUSE	VERDICT	COMMENT
		<p>e) After replacing the battery, the timer for the end-of-life signal shall not reset and the timer must continue from the cumulated end-of-life time which the battery was removed. The timer shall not be able to be reset after 30 days from the original battery end-of-life signal.</p> <p>f) 40.1.7 a), b) and c) shall be re-conducted but with the battery replaced one day prior to the maximum end-of-life time period. A second alarm may be used for this requirement.</p>
40.1.8		<p><i>New clause added;</i></p> <p>In addition to the requirements outlined in 40.1.6 (a), for an alarm that employs a replaceable battery but does not employ an end-of-life timer reset, the tests specified in clauses 40.1.7 (b), (c), (d), (e) and (f) shall be conducted with the battery being replaced on the first day that the end-of-life signal is generated and the last day following the time period that the unit is not reset as defined in 40.1.6 a).</p>
The following changes reflect the September 4, 2018 revision		
48	Info	Variable Ambient Temperature Test
48.2	Info	Effect of shipping and storage
48.2.3		<p><u>Sealed point-of-sale packaging shall only be opened after the conditioning exposure is complete.</u> Sensitivity measurements shall be recorded, before and after the Effect of Shipping and Storage Test in 48.2 using the CO values listed in Table 41.1, Part A – Alarm, and Table 41.1, Part B – False alarm, except the 30-day test is to be conducted for 8 hours. All alarm samples tested as part of the Effect of Shipping and Storage Test in 48.2 shall comply with these requirements.</p>
The following changes reflect the April 5, 2022 revision		
44A		<p><i>New section added;</i></p> <p>One Year (minimum) Sensor Stability Test for CO Sensors</p> <p>A minimum fifteen samples of the carbon monoxide (CO) sensor shall be placed within a closed chamber (test fixture) that shall allow for the following:</p> <p>See standard for details.</p>



CLAUSE	VERDICT	COMMENT
The following changes reflect the October 7, 2022 revision		
40	Info	Electrical Supervision Test
40.3	Info	Battery powered primary or secondary units
		<i>New clause added;</i>
40.3.7		Primary power for commercial vehicles shall be provided by a permanently sealed, nonreplaceable battery installed within the CO alarm and not from an external AC or DC source.
41	Info	Sensitivity Test
41.2	Info	Test equipment
		The carbon monoxide alarm shall be installed in a chamber, having a volume of at least 1 cubic foot (0.0283 m3), constructed so as to permit accurate monitoring and control of chamber air temperature and humidity and oxygen and carbon monoxide concentrations. The following conditions shall be established within the test chamber and maintained throughout the test:
41.2.1		<ul style="list-style-type: none"> a) Ambient temperature at 23 ±3°C (73.4 ±5°F) or a higher temperature if specified by the manufacturer, b) Relative humidity at 50 ±20 percent, c) Oxygen concentration at 20.9 ±1 percent,i <u>c1) Air movement within the test chamber shall be within 16.0 ±7 fpm (0.08 m/s), and</u> d) Supply voltage, if applicable, adjusted to 100 percent of rated input voltage.
		<i>New section added;</i>
		Velocity-Sensitivity Test
44B		44B.1 Test procedure 44B.2 Duct test equipment
		See standard for details.
75	Info	Variable Ambient Temperature and Humidity Test
75.4		All batteries included with Carbon Monoxide alarms intended for use in recreational vehicles, <u>unconditioned areas, or commercial vehicle</u> applications shall at a minimum have a published operational specification range of <u>no greater than</u> minus 20 °C (minus 4 °F) <u>and no less than</u> 60 °C (140 °F). Recommended replacement batteries must also meet the temperature range.



CLAUSE	VERDICT	COMMENT
		<i>New clause added;</i>
75.5		Primary and recommended replacement batteries must identify the maximum and minimum temperature range as specified in 75.4.
		<i>New clause added;</i>
75.6		Batteries shall be tested in accordance with all applicable battery tests outlined within this standard and the battery operating range specified in 75.4 using the methods specified in Battery Tests, Section 64.